

## Dump Insert DI-100 / DI-100-6

# Load Haul Dump



*Shown with optional cab protector*



### Standard Features & Specifications

- 12 Gauge Floor
- 14 Gauge Sides
- Stake Pockets (8)
- One-piece Tailgate w/ Chains
- Monarch Power Unit w/ 20' Cord
- Power Up/Power Down Hydraulics
- Powder Coat Finish (Black only)
- 6,000 lb. Lift Capacity
- 48 Degree Dump Angle

### Options

- Full Height Cab Protector
- Tarp Kit
- Wireless Remote
- Side Extensions
- Hot Dip Galvanizing





1080 South Main Street • Chambersburg, PA 17201  
 (717) 263-6116 • www.bri-mar.com

**Dump Insert**  
**DI-100 (8' unit)**  
**DI-100-6 (6' unit)**

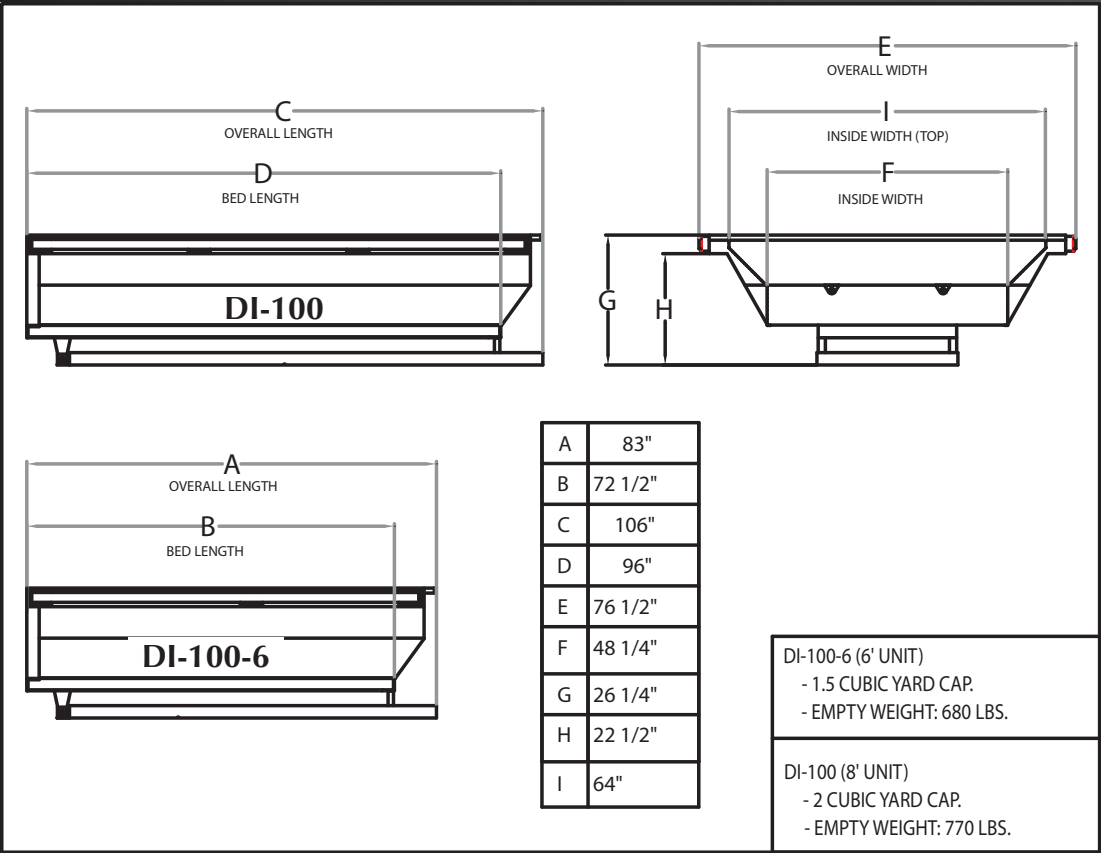

*Cab protector optional*



*Cab protector optional*

Pricing and Specifications subject to change without notification.

# WARRANTY

Bri-mar Manufacturing, LLC, warrants each trailer to be free from defects in material and workmanship for a period of (24) months to the original purchaser from date of purchase, or (30) months from date of manufacture, which ever expires first, under normal wear and rated load capacity.

Bri-mar Manufacturing, LLC, warrants its paint finish to be free from defects as a result of improper surface preparation and application for a period of (12) months to the original purchaser from date of purchase, or (24) months from date of manufacture, which ever expires first, excluding normal wear.

Extended warranty is given to the frame structure on all Heavy Duty trailers. This includes: frame rail, crossmembers, tongue and tongue brace for a period of five (5) years from date of original purchase.

All auxiliary parts, axle assemblies, brake systems, wheels, tires, light systems, hitch couplers, jacks, power units, cylinders, or other accessories or purchased parts are covered by the warranty of the original manufacturer.

The warranty does not cover: normal wear, lack of maintenance, misapplication of use, abuse or negligence, overloading in excess of GVWR on vin sticker, unauthorized modifications and repairs, altered electrical systems, accidents, towing and transportation costs, loss of time and use, damage to towing vehicle, or customer dissatisfaction.

Bri-mar Manufacturing, LLC reserves the right to make changes in design and specifications at any time, without incurring any obligation to owners of trailers previously sold.

This warranty is in lieu of all other warranties, guarantees of agreements, whether expressed or implied, and no other person, agent, dealer, or company is authorized to change, modify, or extend its terms in any manner whatsoever.



1080 South Main Street • Chambersburg, PA 17201  
 (717) 263-6116 • www.bri-mar.com

**Distributed by:**

032910